

Microwave MLC's

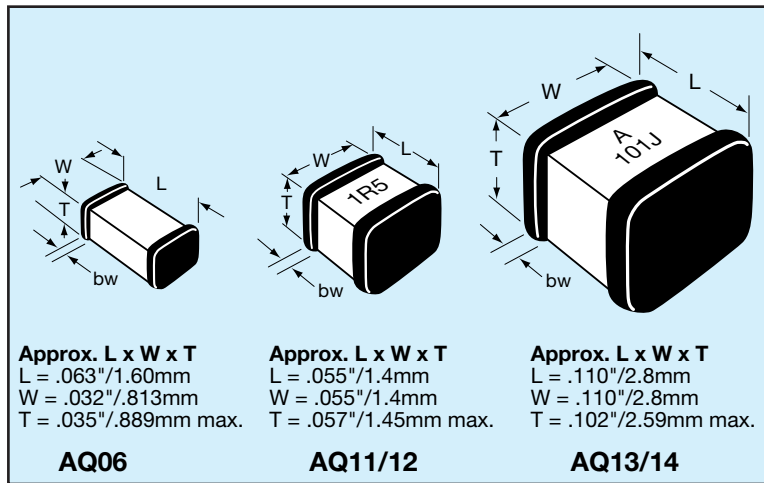

AQ Series



These porcelain and ceramic dielectric multilayer capacitor (MLC) chips are best suited for RF/ Microwave applications typically ranging from 10 MHz to 4.2 GHz. Characteristic is a fine grained, high density, high purity dielectric material impervious to moisture with heavy internal palladium electrodes.

These characteristics lend well to applications requiring:

- 1) high current carrying capabilities;
- 2) high quality factors;
- 3) very low equivalent series resistance;
- 4) very high series resonance;
- 5) excellent stability under stresses of changing voltage, frequency, time and temperature.

MECHANICAL DIMENSIONS: inches (millimeters)

Case	Length (L)	Width (W)	Thickness (T)	Band Width (bw)
AQ06	.063±.006 (1.60±.152)	.032±.006 (.813±.152)	.035 Max. (.889)	.014±.006 (.357 +.152)
AQ11	.055±.015 (1.40±.381)	.055±.015 (1.40±.381)	.020/.057 (.508/1.45)	.010 + .010 -.005 (.254 +.254 -.127)
AQ12	.055 + .015 - .010 (1.40+ .381 - .256)	.055±.015 (1.40±.381)	.020/.057 (.508/1.45)	.010 + .010 -.005 (.254 +.254 -.127)
AQ13	.110±.020 (2.79±.508)	.110±.020 (2.79±.508)	.030/.102 (.762/2.59)	.015±.010 (.381±.254)
AQ14	.110 + .020 - .010 (2.79 +.889 -.508)	.110±.010 (2.79±.508)	.030/.102 (.762/2.59)	.015±.010 (.381±.254)

*For Tape and Reel packaging details see page 59

HOW TO ORDER

<p>AQ</p> <p>AVX Style AQ06, AQ11, AQ12, AQ13, AQ14</p>	<p>11</p> <p>Case Size (See Chart)</p>	<p>E</p> <p>Voltage Code 5 = 50V 1 = 100V E = 150V 2 = 200V 9 = 300V 7 = 500V</p>	<p>M</p> <p>Temperature Coefficient Code M = +90±20ppm/°C (AQ06/11/12/13/14) A = 0±30ppm/°C (AQ11/12/13/14) C = 15% ("J" Termination only) (AQ12/14)</p>	<p>100</p> <p>Capacitance EIA Capacitance Code in pF. First two digits = significant figures or "R" for decimal place. Third digit = number of zeros or after "R" significant figures.</p>	<p>J</p> <p>Capacitance Tolerance Code B = ±.1 pF C = ±.25 pF D = ±.5 pF F = ±1% G = ±2% J = ±5% K = ±10% M = ±20% N = ±30%</p>	<p>A</p> <p>Failure Rate Code A = Not Applicable</p>	<p>1</p> <p>Termination Style Code 1 = Pd/Ag (AQ11/13 only) 7 = Ag/Ni/Au (AQ11/13 only) J = Nickel Barrier Sn/Pb (60/40) - (AQ06/12/14 only)</p>	<p>M</p> <p>Packaging* Code ME = 7" Reel RE = 13" Reel WE = Waffle Pack 1A = 7" Reel (AQ06 only)</p>
--	---	--	---	---	--	---	---	---

PACKAGING

Standard Packaging = Waffle Pack (for T&R packaging see page 59)
AQ11/12 maximum quantity per waffle pack is 100.
AQ13/14 maximum quantity is 80.



ELECTRICAL SPECIFICATIONS

AQ06, AQ11, AQ12, AQ13, AQ14		
	M & A	C
Temperature Coefficient	(M) +90 ±20PPM/°C and (A) 0 ±30PPM/°C	±15%
Capacitance Range	0.1 pF to 5100 pF	0.001µF to 0.1µF
Capacitance Tolerance	±0.1 pF to ±20%	±10%, ±20%, ±30%
Operating Temperature	-55°C + 125°C	-55°C to +125°C
Quality Factor or Dissipation Factor	Per MIL-PRF-55681/4	2.5% @ 1kHz
Insulation Resistance	Per MIL-PRF-55681 10 ⁶ megohm to 470 pF @ +25°C 10 ⁵ megohm to 470 pF @ +125°C 10 ⁵ megohm above 470 pF @ +25°C 10 ⁴ megohm above 470 pF @ +125°C	10 ⁴ megohm min @ 25°C & R VDC 10 ³ megohm min @ 25°C & R VDC
Aging	None	<3% per decade hour
Piezoelectric Effects	None	None
Dielectric Withstanding Voltage	2.5 x rated voltage (for 500V rated 1.5 x rated voltage)	2.5 x rated voltage (for 500V rated 1.5 x rated voltage)

ENVIRONMENTAL CHARACTERISTICS

Will meet or exceed performance characteristics as outlined in MIL-PRF-55681/4.

REQUIREMENT	MIL-STD-202 METHOD
Life	108, Condition F
Shock	213, Condition J
Vibration	204, Condition B
Immersion	104, Condition B
Salt Spray	101, Condition B
Solderability	208
Thermal Shock	107, Condition B
Terminal Strength	211
Temperature Cycling	102, Condition C
Moisture Resistance	106
Barometric Pressure	105, Condition B
Resistance to Soldering Heat	210, Condition C

QUALITY FACTOR vs. FREQUENCY (Typical)

Capacitance	@ 30 MHz	@ 150 MHz	@ 500 MHz	@ 1000 MHz
1 pF	30000	4000	800	350
10 pF	9000	2000	400	150
30 pF	5000	800	200	60
100 pF	2800	400	70	25
200 pF	1500	250	40	12

CAPACITANCE AND SIZE vs. SERIES SELF RESONANT FREQUENCY (Typical)

DIMENSIONS: inches (millimeters)

Case	Size (Nominal)	1 pF	10 pF	50 pF	100 pF
AQ06	.063 x .032 x .035 (1.60 x .813 x .889)	9.6 GHz	3.2 GHz	1.5 GHz	1.0 GHz
AQ11/12	.055 x .055 x .057 (1.40 x 1.40 x 1.45)	9.6 GHz	3.2 GHz	1.5 GHz	1.0 GHz
AQ13/14	.110 x .110 x .102 (2.79 x 2.79 x 2.59)	6.4 GHz	2.2 GHz	1.0 GHz	0.7 GHz

Microwave MLC's



AQ Series Available Capacitance/Size/WVDC/T.C.

**TABLE I: TC: M (+90±20PPM/°C)
CASE SIZE 06, 11, 12, 13 & 14**

DIMENSIONS: inches (millimeters)

Case	Length	Width	Thickness	Band Width	Avail. Term.
06	.063±.006 (1.60±.152)	.032±.006 (.813±.152)	.035 Max. (.889)	.014±.006 (.357 ±.152)	J
11	.055±.015 (1.40±.381)	.055±.015 (1.40±.381)	.020/.057 (.508/1.45)	.010 +.010 -.005 (.254 +.254 -.127)	1 & 7
12	.055±.025 (1.40±.635)	.055±.015 (1.40±.381)	.020/.057 (.508/1.45)	.010 +.010 -.005 (.254 +.254 -.127)	J
13	.110±.020 (2.79±.508)	.110±.020 (2.79±.508)	.030/.102 (.762/2.59)	.015±.010 (.381±.254)	1 & 7
14	.110 +0.035 -0.020 (2.79 +.889 -.508)	.110±.020 (2.79±.508)	.030/.102 (.762/2.59)	.015±.010 (.381±.254)	J

Case: AQ06			Case: AQ11, AQ12			Case: AQ13, AQ14					
Cap. pF	Cap. Tol.	WVDC	Cap. pF	Cap. Tol.	WVDC	Cap. pF	Cap. Tol.	WVDC	Cap. pF	Cap. Tol.	WVDC
0.1	B	150	0.1	B	150	0.1	B	500	100	F, G, J, K, M	500
0.2	B	150	0.2	B	150	0.2	B	500	110	F, G, J, K, M	300
0.3	B,C	150	0.3	B,C	150	0.3	B,C	500	120	F, G, J, K, M	300
0.4	B,C	150	0.4	B,C	150	0.4	B,C	500	130	F, G, J, K, M	300
0.5	B, C, D	150	0.5	B, C, D	150	0.5	B, C, D	500	150	F, G, J, K, M	300
0.6	B, C, D	150	0.6	B, C, D	150	0.6	B, C, D	500	160	F, G, J, K, M	300
0.7	B, C, D	150	0.7	B, C, D	150	0.7	B, C, D	500	180	F, G, J, K, M	300
0.8	B, C, D	150	0.8	B, C, D	150	0.8	B, C, D	500	200	F, G, J, K, M	300
0.9	B, C, D	150	0.9	B, C, D	150	0.9	B, C, D	500	220	F, G, J, K, M	200
1.0	B, C, D	150	1.0	B, C, D	150	1.0	B, C, D	500	240	F, G, J, K, M	200
1.1	B, C, D	150	1.1	B, C, D	150	1.1	B, C, D	500	270	F, G, J, K, M	200
1.2	B, C, D	150	1.2	B, C, D	150	1.2	B, C, D	500	300	F, G, J, K, M	200
1.3	B, C, D	150	1.3	B, C, D	150	1.3	B, C, D	500	330	F, G, J, K, M	200
1.4	B, C, D	150	1.4	B, C, D	150	1.4	B, C, D	500	360	F, G, J, K, M	200
1.5	B, C, D	150	1.5	B, C, D	150	1.5	B, C, D	500	390	F, G, J, K, M	200
1.6	B, C, D	150	1.6	B, C, D	150	1.6	B, C, D	500	430	F, G, J, K, M	200
1.7	B, C, D	150	1.7	B, C, D	150	1.7	B, C, D	500	470	F, G, J, K, M	200
1.8	B, C, D	150	1.8	B, C, D	150	1.8	B, C, D	500	510	F, G, J, K, M	150
1.9	B, C, D	150	1.9	B, C, D	150	1.9	B, C, D	500	560	F, G, J, K, M	150
2.0	B, C, D	150	2.0	B, C, D	150	2.0	B, C, D	500	620	F, G, J, K, M	150
2.2	B, C, D	150	2.2	B, C, D	150	2.2	B, C, D	500	680	F, G, J, K, M	150
2.4	B, C, D	150	2.4	B, C, D	150	2.4	B, C, D	500	750	F, G, J, K, M	150
2.7	B, C, D	150	2.7	B, C, D	150	2.7	B, C, D	500	820	F, G, J, K, M	150
3.0	B, C, D	150	3.0	B, C, D	150	3.0	B, C, D	500	910	F, G, J, K, M	150
3.3	B, C, D	150	3.3	B, C, D	150	3.3	B, C, D	500	1000	F, G, J, K, M	150
3.6	B, C, D	150	3.6	B, C, D	150	3.6	B, C, D	500			
3.9	B, C, D	150	3.9	B, C, D	150	3.9	B, C, D	500			
4.3	B, C, D	150	4.3	B, C, D	150	4.3	B, C, D	500			
4.7	B, C, D	150	4.7	B, C, D	150	4.7	B, C, D	500			
5.1	B, C, D	150	5.1	B, C, D	150	5.1	B, C, D	500			
5.6	B, C, D	150	5.6	B, C, D	150	5.6	B, C, D	500			
6.2	B, C, D	150	6.2	B, C, D	150	6.2	B, C, D	500			
6.8	B, C, J, K, M	150	6.8	B, C, J, K, M	150	6.8	B, C, J, K, M	500			
7.5	B, C, J, K, M	150	7.5	B, C, J, K, M	150	7.5	B, C, J, K, M	500			
8.2	B, C, J, K, M	150	8.2	B, C, J, K, M	150	8.2	B, C, J, K, M	500			
9.1	B, C, J, K, M	150	9.1	B, C, J, K, M	150	9.1	B, C, J, K, M	500			
10	F, G, J, K, M	150	10	F, G, J, K, M	150	10	F, G, J, K, M	500			
11	F, G, J, K, M	150	11	F, G, J, K, M	150	11	F, G, J, K, M	500			
12	F, G, J, K, M	150	12	F, G, J, K, M	150	12	F, G, J, K, M	500			
13	F, G, J, K, M	150	13	F, G, J, K, M	150	13	F, G, J, K, M	500			
15	F, G, J, K, M	150	15	F, G, J, K, M	150	15	F, G, J, K, M	500			
16	F, G, J, K, M	150	16	F, G, J, K, M	150	16	F, G, J, K, M	500			
18	F, G, J, K, M	150	18	F, G, J, K, M	150	18	F, G, J, K, M	500			
20	F, G, J, K, M	150	20	F, G, J, K, M	150	20	F, G, J, K, M	500			
22	F, G, J, K, M	150	22	F, G, J, K, M	150	22	F, G, J, K, M	500			
24	F, G, J, K, M	150	24	F, G, J, K, M	150	24	F, G, J, K, M	500			
27	F, G, J, K, M	150	27	F, G, J, K, M	150	27	F, G, J, K, M	500			
30	F, G, J, K, M	150	30	F, G, J, K, M	150	30	F, G, J, K, M	500			
33	F, G, J, K, M	150	33	F, G, J, K, M	150	33	F, G, J, K, M	500			
36	F, G, J, K, M	150	36	F, G, J, K, M	150	36	F, G, J, K, M	500			
39	F, G, J, K, M	150	39	F, G, J, K, M	150	39	F, G, J, K, M	500			
43	F, G, J, K, M	150	43	F, G, J, K, M	150	43	F, G, J, K, M	500			
47	F, G, J, K, M	150	47	F, G, J, K, M	150	47	F, G, J, K, M	500			
51	F, G, J, K, M	150	51	F, G, J, K, M	150	51	F, G, J, K, M	500			
56	F, G, J, K, M	150	56	F, G, J, K, M	150	56	F, G, J, K, M	500			
62	F, G, J, K, M	150	62	F, G, J, K, M	150	62	F, G, J, K, M	500			
68	F, G, J, K, M	50	68	F, G, J, K, M	150	68	F, G, J, K, M	500			
75	F, G, J, K, M	50	75	F, G, J, K, M	150	75	F, G, J, K, M	500			
82	F, G, J, K, M	50	82	F, G, J, K, M	150	82	F, G, J, K, M	500			
91	F, G, J, K, M	50	91	F, G, J, K, M	150	91	F, G, J, K, M	500			
100	F, G, J, K, M	50	100	F, G, J, K, M	150						
120	F, G, J, K, M	50									



Microwave MLC's



AQ Series Available Capacitance/Size/WVDC/T.C.

**TABLE II: TC: A (0±30PPM/°C)
CASE SIZE 11, 12, 13 & 14**

DIMENSIONS: inches (millimeters)

Case	Length	Width	Thickness	Band Width	Avail. Term.
11	.055±.015 (1.40±.381)	.055±.015 (1.40±.381)	.020/.057 (.508/1.45)	.010 +.010 -.005 (.254 +.254 -.127)	1 & 7
12	.055±.025 (1.40±.635)	.055±.015 (1.40±.381)	.020/.057 (.508/1.45)	.010 +.010 -.005 (.254 +.254 -.127)	J
13	.110±.020 (2.79±.508)	.110±.020 (2.79±.508)	.030/.102 (.762/2.59)	.015±.010 (.381±.254)	1 & 7
14	.110 +0.035 -0.020 (2.79 +.889 -.508)	.110±.020 (2.79±.508)	.030/.102 (.762/2.59)	.015±.010 (.381±.254)	J

Case: AQ11, AQ12						Case: AQ13, AQ14					
Cap. pF	Cap. Tol.	WVDC	Cap. pF	Cap. Tol.	WVDC	Cap. pF	Cap. Tol.	WVDC	Cap. pF	Cap. Tol.	WVDC
0.1	B	150	24	F, G, J, K, M	150	0.1	B	500	51	F, G, J, K, M	500
0.2	B	150	27	F, G, J, K, M	150	0.2	B	500	56	F, G, J, K, M	500
0.3	B,C	150	30	F, G, J, K, M	150	0.3	B,C	500	62	F, G, J, K, M	500
0.4	B,C	150	33	F, G, J, K, M	150	0.4	B,C	500	68	F, G, J, K, M	500
0.5	B, C, D	150	36	F, G, J, K, M	150	0.5	B, C, D	500	75	F, G, J, K, M	500
0.6	B, C, D	150	39	F, G, J, K, M	150	0.6	B, C, D	500	82	F, G, J, K, M	500
0.7	B, C, D	150	43	F, G, J, K, M	150	0.7	B, C, D	500	91	F, G, J, K, M	500
0.8	B, C, D	150	47	F, G, J, K, M	150	0.8	B, C, D	500	100	F, G, J, K, M	500
0.9	B, C, D	150	51	F, G, J, K, M	150	0.9	B, C, D	500	110	F, G, J, K, M	300
1.0	B, C, D	150	56	F, G, J, K, M	150	1.0	B, C, D	500	120	F, G, J, K, M	300
1.1	B, C, D	150	62	F, G, J, K, M	150	1.1	B, C, D	500	130	F, G, J, K, M	300
1.2	B, C, D	150	68	F, G, J, K, M	150	1.2	B, C, D	500	150	F, G, J, K, M	300
1.3	B, C, D	150	75	F, G, J, K, M	150	1.3	B, C, D	500	160	F, G, J, K, M	300
1.4	B, C, D	150	82	F, G, J, K, M	150	1.4	B, C, D	500	180	F, G, J, K, M	300
1.5	B, C, D	150	91	F, G, J, K, M	150	1.5	B, C, D	500	200	F, G, J, K, M	300
1.6	B, C, D	150	100	F, G, J, K, M	150	1.6	B, C, D	500	220	F, G, J, K, M	200
1.7	B, C, D	150	110	F, G, J, K, M	50	1.7	B, C, D	500	240	F, G, J, K, M	200
1.8	B, C, D	150	120	F, G, J, K, M	50	1.8	B, C, D	500	270	F, G, J, K, M	200
1.9	B, C, D	150	130	F, G, J, K, M	50	1.9	B, C, D	500	300	F, G, J, K, M	200
2.0	B, C, D	150	150	F, G, J, K, M	50	2.0	B, C, D	500	330	F, G, J, K, M	200
2.2	B, C, D	150	160	F, G, J, K, M	50	2.2	B, C, D	500	360	F, G, J, K, M	200
2.4	B, C, D	150	180	F, G, J, K, M	50	2.4	B, C, D	500	390	F, G, J, K, M	200
2.7	B, C, D	150	200	F, G, J, K, M	50	2.7	B, C, D	500	430	F, G, J, K, M	200
3.0	B, C, D	150	220	F, G, J, K, M	50	3.0	B, C, D	500	470	F, G, J, K, M	200
3.3	B, C, D	150	240	F, G, J, K, M	50	3.3	B, C, D	500	510	F, G, J, K, M	150
3.6	B, C, D	150	270	F, G, J, K, M	50	3.6	B, C, D	500	560	F, G, J, K, M	150
3.9	B, C, D	150	300	F, G, J, K, M	50	3.9	B, C, D	500	620	F, G, J, K, M	150
4.3	B, C, D	150	330	F, G, J, K, M	50	4.3	B, C, D	500	680	F, G, J, K, M	150
4.7	B, C, D	150	360	F, G, J, K, M	50	4.7	B, C, D	500	750	F, G, J, K, M	150
5.1	B, C, D	150	390	F, G, J, K, M	50	5.1	B, C, D	500	820	F, G, J, K, M	150
5.6	B, C, D	150	430	F, G, J, K, M	50	5.6	B, C, D	500	910	F, G, J, K, M	150
6.2	B, C, D	150	470	F, G, J, K, M	50	6.2	B, C, D	500	1000	F, G, J, K, M	150
6.8	B, C, J, K, M	150	510	F, G, J, K, M	50	6.8	B, C, J, K, M	500	1100	F, G, J, K, M	50
7.5	B, C, J, K, M	150	560	F, G, J, K, M	50	7.5	B, C, J, K, M	500	1200	F, G, J, K, M	50
8.2	B, C, J, K, M	150	620	F, G, J, K, M	50	8.2	B, C, J, K, M	500	1300	F, G, J, K, M	50
9.1	B, C, J, K, M	150	680	F, G, J, K, M	50	9.1	B, C, J, K, M	500	1500	F, G, J, K, M	50
10	F, G, J, K, M	150	750	F, G, J, K, M	50	10	F, G, J, K, M	500	1600	F, G, J, K, M	50
11	F, G, J, K, M	150	820	F, G, J, K, M	50	11	F, G, J, K, M	500	1800	F, G, J, K, M	50
12	F, G, J, K, M	150	910	F, G, J, K, M	50	12	F, G, J, K, M	500	2000	F, G, J, K, M	50
13	F, G, J, K, M	150	1000	F, G, J, K, M	50	13	F, G, J, K, M	500	2200	F, G, J, K, M	50
15	F, G, J, K, M	150				15	F, G, J, K, M	500	2400	F, G, J, K, M	50
16	F, G, J, K, M	150				16	F, G, J, K, M	500	2700	F, G, J, K, M	50
18	F, G, J, K, M	150				18	F, G, J, K, M	500	3000	F, G, J, K, M	50
20	F, G, J, K, M	150				20	F, G, J, K, M	500	3300	F, G, J, K, M	50
22	F, G, J, K, M	150				22	F, G, J, K, M	500	3600	F, G, J, K, M	50
						24	F, G, J, K, M	500	3900	F, G, J, K, M	50
						27	F, G, J, K, M	500	4300	F, G, J, K, M	50
						30	F, G, J, K, M	500	4700	F, G, J, K, M	50
						33	F, G, J, K, M	500	5000	F, G, J, K, M	50
						36	F, G, J, K, M	500	5100	F, G, J, K, M	50
						39	F, G, J, K, M	500			
						43	F, G, J, K, M	500			
						47	F, G, J, K, M	500			

**TABLE III: TC: C (±15%)
CASE SIZE 12 & 14**

Case: AQ12						Case: AQ14					
Cap. pF	Cap. Tol.	WVDC	Cap. pF	Cap. Tol.	WVDC	Cap. pF	Cap. Tol.	WVDC	Cap. pF	Cap. Tol.	WVDC
1000	K, M, N	50	3900	K, M, N	50	5000	K, M, N	50	27000	K, M, N	50
1200	K, M, N	50	4700	K, M, N	50	6800	K, M, N	50	33000	K, M, N	50
1500	K, M, N	50	5100	K, M, N	50	8200	K, M, N	50	39000	K, M, N	50
1800	K, M, N	50	5600	K, M, N	50	10000	K, M, N	50	47000	K, M, N	50
2000	K, M, N	50	6800	K, M, N	50	12000	K, M, N	50	68000	K, M, N	50
2200	K, M, N	50	8200	K, M, N	50	15000	K, M, N	50	82000	K, M, N	50
2700	K, M, N	50	10000	K, M, N	50	18000	K, M, N	50	100000	K, M, N	50
3300	K, M, N	50									

