

Ultrafast Plastic Rectifiers

Reverse Voltage 400 to 600V

Forward Current 4.0A



DO-201AD

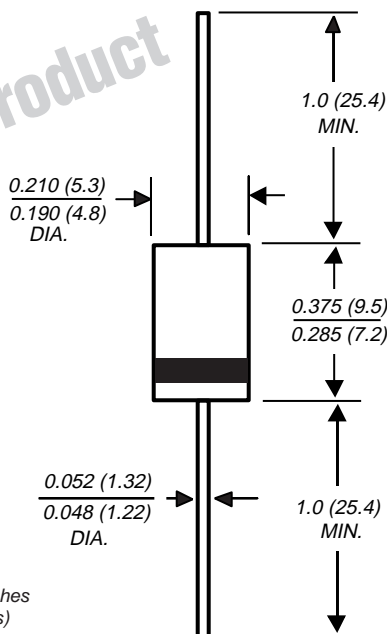

New Product

Features

- Plastic package has Underwriters Laboratories Flammability Classification 94V-0
- Ideally suited for use in very high frequency switching power supplies, inverters and as free wheeling diodes
- Ultrafast recovery time for high efficiency
- Excellent high temperature switching
- Glass passivated junction
- High temperature soldering guaranteed: 250°C/10 seconds, 0.375" (9.5mm) lead length, 5 lbs. (2.3kg) tension

Mechanical Data

Case: JEDEC DO-201AD molded plastic body over passivated chip

Terminals: Plated axial leads, solderable per MIL-STD-750, Method 2026

Polarity: Color band denotes cathode end

Mounting Position: Any

Weight: 0.045oz., 1.2g

Maximum Ratings & Thermal Characteristics Ratings at 25°C ambient temperature unless otherwise specified.

Parameter	Symbol	MUR440	MUR460	Unit
Maximum repetitive peak reverse voltage	V_{RRM}	400	600	V
Working peak reverse voltage	V_{RWM}	400	600	V
Maximum DC blocking voltage	V_{DC}	400	600	V
Maximum average forward rectified current (See figure 1)	$I_{F(AV)}$	4.0		A
Peak forward surge current 8.3 ms single half sine-wave superimposed on rated load (JEDEC Method)	I_{FSM}	150		A
Typical thermal resistance junction to ambient ⁽²⁾	$R_{\theta JA}$	28		°C/W
Operating junction and storage temperature range	T_J, T_{STG}	-65 to +175°C		°C

Electrical Characteristics Ratings at 25°C ambient temperature unless otherwise specified.

Parameter	Symbol	MUR440	MUR460	Unit
Maximum instantaneous forward voltage (NOTE 1) at 3.0A, $T_J = 150^\circ\text{C}$ at 3.0A, $T_J = 25^\circ\text{C}$ at 4.0A, $T_J = 25^\circ\text{C}$	V_F	1.05 1.25 1.28		V
Maximum instantaneous reverse current at rated DC blocking voltage ⁽¹⁾ $T_J = 25^\circ\text{C}$ $T_J = 150^\circ\text{C}$	I_R	10 250		μA
Max. reverse recovery time at $I_F = 0.5\text{A}$, $I_R = 1.0\text{A}$, $I_{rr} = 0.25\text{A}$	t_{rr}	50		ns
Maximum reverse recovery time at, $I_F = 1.0\text{A}$, $di/dt = 50\text{A}/\mu\text{s}$, $V_R = 30\text{V}$, $I_{rr} = 10\% I_{RM}$	t_{rr}	75		ns
Maximum forward recovery time ($I_F = 1.0\text{A}$, $di/dt = 100\text{A}/\mu\text{s}$, Rec. to 1.0V)	t_{fr}	50		ns

Notes:

(1) Pulse test: $t_p = 300\mu\text{s}$, duty cycle $\leq 2\%$

(2) Lead length = 1/2" on P.C. board with 1.5" x 1.5" copper surface

Ratings and Characteristic Curves (T_A = 25°C unless otherwise noted)

Fig. 1 – Forward Current Derating Curve

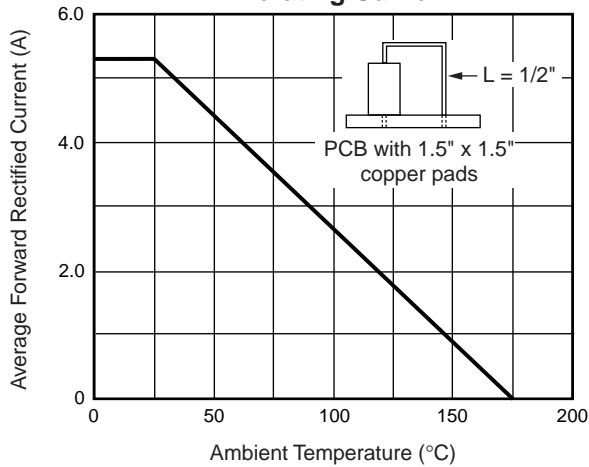

Fig. 2 – Maximum Non-Repetitive Peak Forward Surge Current

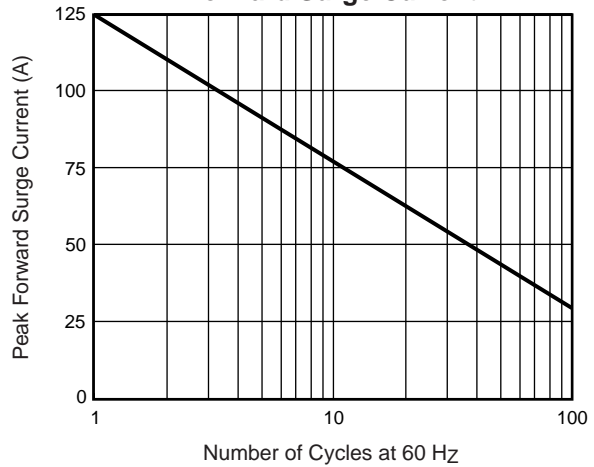

Fig. 3 – MUR460 Typical Instantaneous Forward Characteristics

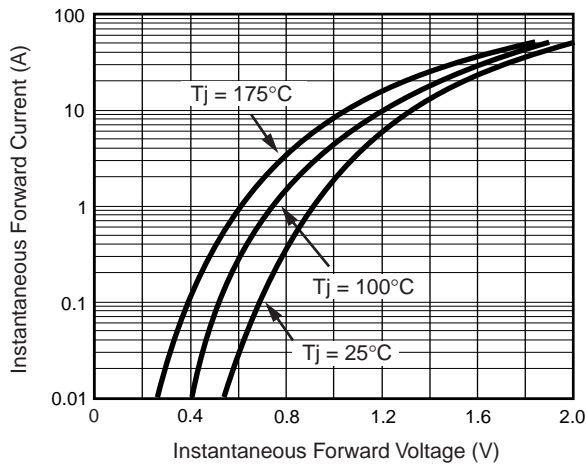

Fig. 4 – MUR460 Typical Reverse Characteristics

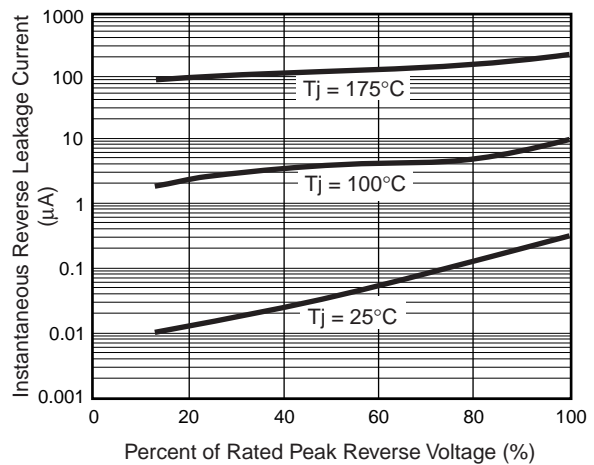

Fig. 5 – Typical Junction Capacitance per Leg

