

# High Power Factor Preregulator

## FEATURES

- Complete 8-pin Power Factor Solution
- Reduced External Components
- RMS Line Voltage Compensation
- Precision Multiplier/Squarer/Divider
- Internal 75kHz Synchronizable Oscillator
- Average Current Mode PWM Control
- Overvoltage Protection Comparator
- High Current, Clamped Gate Driver

## DESCRIPTION

The UC3853 provides simple, yet high performance active power factor correction. Using the same control technique as the UC1854, this 8-pin device exploits a simplified architecture and an internal oscillator to minimize external component count. The UC3853 incorporates a precision multiplier/squarer/divider circuit, voltage and current loop error amplifiers, and a precision voltage reference to implement average current mode control with RMS line voltage compensation. This control technique maintains constant loop gain with changes in input voltage, which minimizes input line current distortion over the worldwide input voltage range.

The internal 75kHz oscillator includes an external clock input, allowing synchronization to downstream converters. Additionally, the device features an overvoltage protection comparator, a clamped MOSFET gate driver which self-biases low during undervoltage lockout, and low startup and supply current.

These devices are available in 8-pin plastic and ceramic dual in-line (DIP) packages, and 8-lead small outline (SOIC) packages. The UC1853 is specified for operation from  $-55^{\circ}\text{C}$  to  $+125^{\circ}\text{C}$ , the UC2853 is specified for operation from  $-25^{\circ}\text{C}$  to  $+85^{\circ}\text{C}$ , and the UC3853 is specified for operation from  $0^{\circ}\text{C}$  to  $+70^{\circ}\text{C}$ .

## BLOCK DIAGRAM

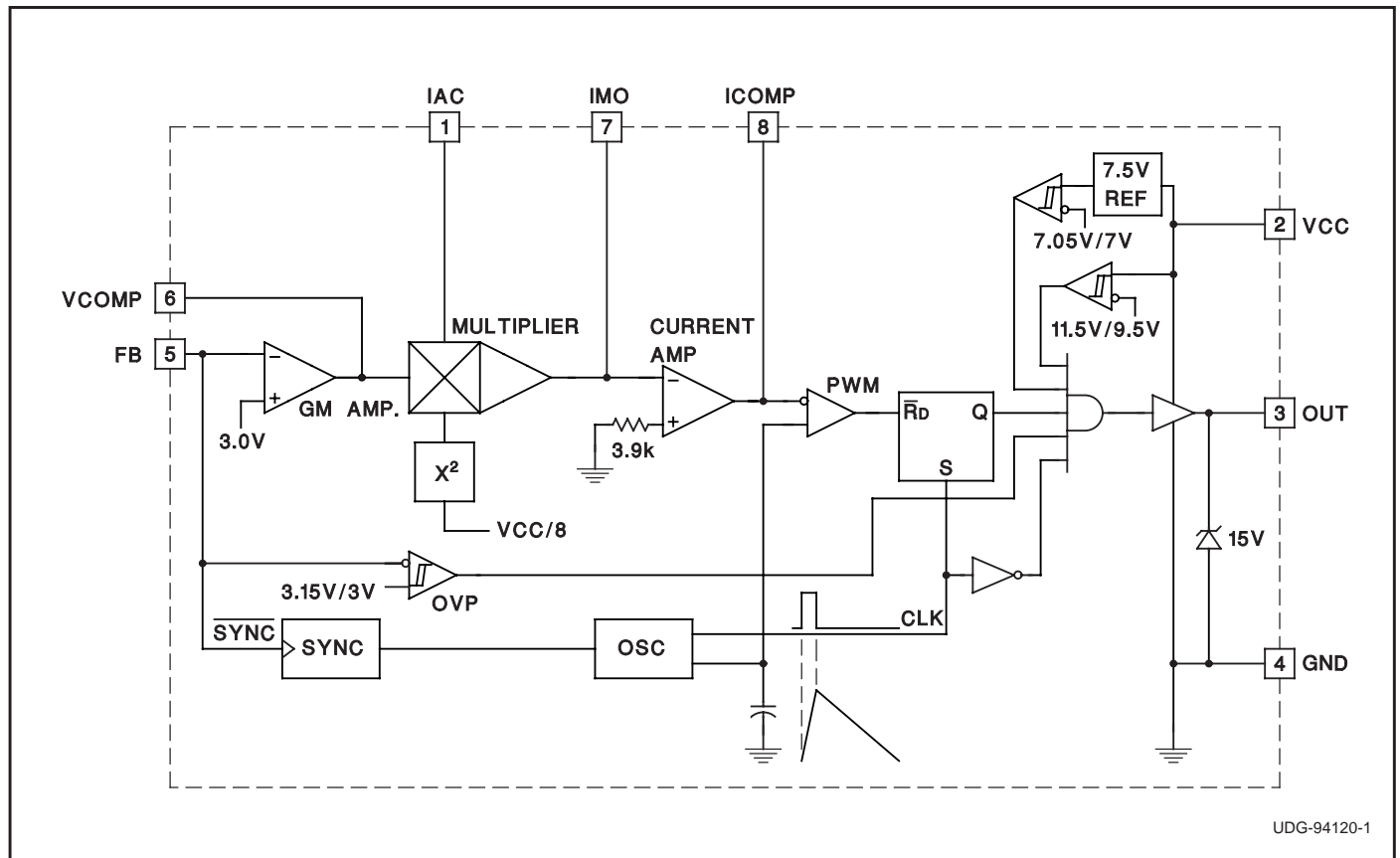

## ABSOLUTE MAXIMUM RATINGS

Supply Voltage (VCC) . . . . .	40V
Output Drive Current,	
Continuous . . . . .	0.125A
Peak . . . . .	0.5A
Output Minimum Voltage . . . . .	-0.3V
IAC Maximum Input Current . . . . .	1mA
IMO Maximum Output Current . . . . .	-2mA
IMO Minimum Voltage . . . . .	-0.3V
FB Maximum Input Voltage . . . . .	5V
VCOMP Maximum Voltage . . . . .	6.2V
ICOMP Sourcing Current . . . . .	Self-Limiting
ICOMP Sinking Current . . . . .	20mA
ICOMP Maximum Voltage . . . . .	7.2V
Storage Temperature . . . . .	-65°C to +150°C
Junction Temperature . . . . .	-55°C to +150°C
Lead Temperature (Soldering, 10 sec.) . . . . .	+300°C

All voltages with respect to GND. Currents are positive into, negative out of the specified terminal. Consult Packaging Section of Databook for thermal limitations and considerations of packages.

## CONNECTION DIAGRAM

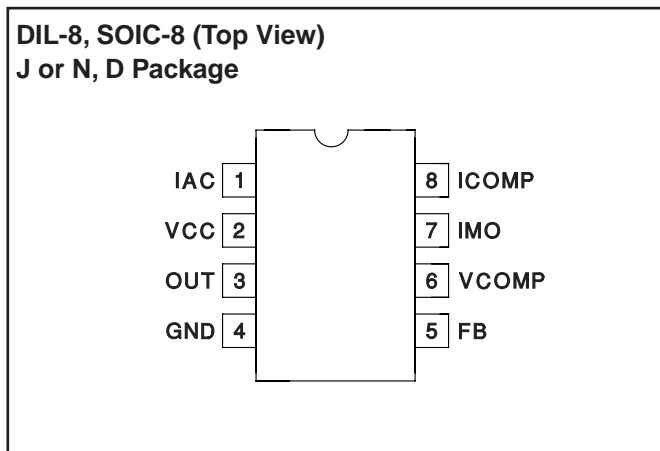

## ELECTRICAL CHARACTERISTICS

Unless otherwise stated, these parameters apply for  $T_A = -55^\circ\text{C}$  to  $+125^\circ\text{C}$  for the UC1853;  $-25^\circ\text{C}$  to  $+85^\circ\text{C}$  for the 2853; and  $0^\circ\text{C}$  to  $+70^\circ\text{C}$  for the UC3853;  $V_{CC} = 16\text{V}$ ,  $V_{FB} = 3\text{V}$ ,  $I_{AC} = 100\mu\text{A}$ ,  $V_{VCOMP} = 3.75\text{V}$ ,  $V_{ICOMP} = 3\text{V}$ ,  $T_A = T_J$ .

PARAMETER	TEST CONDITIONS	MIN	TYP	MAX	UNITS
<b>Undervoltage Lockout Section</b>					
VCC Turn-on Threshold	$V_{VCOMP}$ , $V_{ICOMP}$ Open		11.5	13	V
Hysteresis		1.5	1.8	2.1	V
<b>Supply Current Section</b>					
$I_{VCC}$ Startup	$V_{CC} = 8\text{V}$ , $I_{AC} = 100\mu\text{A}$ ; $V_{VCOMP}$ , $V_{ICOMP}$ Open		250	500	$\mu\text{A}$
$I_{VCC}$	$I_{AC} = 0\mu\text{A}$ , $V_{ICOMP} = 0\text{V}$		10	15	mA
<b>Voltage Loop Error Amplifier Section</b>					
Transconductance	$I_{OUT} = \pm 20\mu\text{A}$ 0-70C	300	450	575	$\mu\text{mho}$
	Temperature	135		640	$\mu\text{mho}$
Input Voltage	0-70C	2.925	3	3.075	V
	Temperature	2.9		3.1	V
AVOL	$V_{VCOMP} = 1\text{V} - 4\text{V}$	50	60		dB
Output Sink Current	$V_{FB} = 3.2\text{V}$ , $V_{VCOMP} = 3.75\text{V}$	20	50		$\mu\text{A}$
Output Source Current	$V_{FB} = 2.8\text{V}$ , $V_{VCOMP} = 3.75\text{V}$		-50	-20	$\mu\text{A}$
Output Voltage High		5.5	6		V
Output Voltage Low			0.6	0.9	V
<b>Current Loop Error Amplifier Section</b>					
Offset Voltage		0		6	mV
Voltage Gain	$V_{ICOMP} = 1\text{V} - 4\text{V}$		70		dB
Sink Current	$V_{IMO} = 100\text{mV}$ , $V_{ICOMP} = 3\text{V}$	1			mA
Source Current	$V_{IMO} = -0.1\text{V}$ , $V_{ICOMP} = 3\text{V}$		-150	-80	$\mu\text{A}$
Output High	$I_{ICOMP} = -50\text{mA}$	6	6.8		V
Output Low	$I_{ICOMP} = 50\mu\text{A}$		0.3	0.8	V
PWM Modulator Gain	$V_{ICOMP} = 2\text{V} - 3\text{V}$ (Note 1)		20		%/V

**ELECTRICAL CHARACTERISTICS**  
**(continued)**

Unless otherwise stated, these parameters apply for  $T_A = -55^\circ\text{C}$  to  $+125^\circ\text{C}$  for the UC1853;  $-25^\circ\text{C}$  to  $+85^\circ\text{C}$  for the 2853; and  $0^\circ\text{C}$  to  $+70^\circ\text{C}$  for the UC3853;  $V_{CC} = 16\text{V}$ ,  $V_{FB} = 3\text{V}$ ,  $I_{AC} = 100\mu\text{A}$ ,  $V_{VCOMP} = 3.75\text{V}$ ,  $V_{ICOMP} = 3\text{V}$ ,  $T_A = T_J$ .

PARAMETER	TEST CONDITIONS	MIN	TYP	MAX	UNITS
<b>Multiplier Section</b>					
Output Current – IAC Limited	$V_{CC} = 11\text{V}$ , $V_{VCOMP} = 6\text{V}$	-230	-200	-170	$\mu\text{A}$
Output Current – Zero	$I_{AC} = 0\mu\text{A}$	-2	-0.2	2	$\mu\text{A}$
Output Current – Power Limited	$V_{CC} = 12\text{V}$ , $V_{VCOMP} = 5.5\text{V}$	-236	-178	-168	$\mu\text{A}$
Output Current	$V_{CC} = 12\text{V}$ , $V_{VCOMP} = 2\text{V}$		-22		$\mu\text{A}$
	$V_{CC} = 12\text{V}$ , $V_{VCOMP} = 5\text{V}$		-156		$\mu\text{A}$
	$V_{CC} = 40\text{V}$ , $V_{VCOMP} = 2\text{V}$		-2		$\mu\text{A}$
	$V_{CC} = 40\text{V}$ , $V_{VCOMP} = 5\text{V}$		-14		$\mu\text{A}$
Multiplier Gain Constant	$V_{CC} = 12\text{V}$ , $V_{VCOMP} = 5.5\text{V}$ (Note 2)	-1.05	-0.9	-0.75	$\text{V}^{-1}$
<b>Oscillator Section</b>					
Oscillator Initial Frequency	$T_A = 25^\circ\text{C}$	67.5	75	82.5	kHz
Oscillator Frequency	Line, Load, Temperature	56	75	94	kHz
Synchronization Frequency Range				100	kHz
Synchronization Pulse Amplitude	Pulse slew rate = $100\text{V}/\mu\text{sec}$ (Note 3)		2		V
<b>Output Driver Section</b>					
Maximum Output Voltage	0mA load, $V_{CC} = 20\text{V}$	12	15	17.5	V
Output High	0mA load, $V_{CC} = 12\text{V}$ , ref. to $V_{CC}$	-2.7	-1.7		V
	-50mA load, $V_{CC} = 12\text{V}$ , ref. to $V_{CC}$	-3	-2.2		V
Output Low (Device Inactive)	$V_{CC} = 0\text{V}$ , 20mA load (Sinking)		0.9	2.0	V
Output Low (Device Active)	50mA load (Sinking)		0.5	1	V
OUT Rise Time	1nF from OUT to GND		55	100	ns
OUT Fall Time	1nF from OUT to GND		35	100	ns
OUT Maximum Duty Cycle	$V_{ICOMP} = 0\text{V}$	88	93		%
<b>OVP Comparator Section</b>					
Threshold Voltage	Volts Above EA Input V	90	150		mV
Hysteresis			80		mV

Note 1:

$$PWM \text{ modulator gain} = \frac{\Delta DutyCycle}{\Delta V_{ICOMP}}$$

Note 2:

$$Gain \text{ constant } (K) = \frac{I_{AC} \cdot (V_{COMP} - 1.5\text{V})}{I_{MO} \cdot V_{CC} \cdot \frac{V_{CC}}{64}}, \quad V_{CC} = 12\text{V}.$$

Note 3:

Synchronization is accomplished with a falling edge of 2V magnitude and  $100\text{V}/\mu\text{sec}$  slew rate.

## PIN DESCRIPTIONS

**FB:** Voltage Amplifier Inverting Input, Overvoltage Comparator Input, Sync Input. This pin serves three functions. FB accepts a fraction of the power factor corrected output voltage through a voltage divider, and is nominally regulated to 3V. FB voltages 5% greater than nominal will trip the overvoltage comparator, and shut down the output stage until the output voltage drops 5%. The internal oscillator can be synchronized through FB by injecting a 2V clock signal through a capacitor. To prevent false tripping of the overvoltage comparator, the clock signal must have a fast falling edge, but a slow rising edge. See Application Note U-159 for more information.

**GND:** Ground. All voltages are measured with respect to GND. The VCC bypass capacitor should be connected to ground as close to the GND pin as possible.

**IAC:** AC Waveform Input. This input provides voltage waveform information to the multiplier. The current loop will try to produce a current waveform with the same shape as the IAC signal. IAC is a low impedance input, nominally at 2V, which accepts a current proportional to the input voltage. Connect a resistor from the rectified input line to IAC which will conduct 500mA at maximum line voltage.

**IMO:** Multiplier Output and Current Sense Inverting Input. The output of the multiplier and the inverting input of the current amplifier are connected together at IMO. Avoid bringing this input below -0.5V to prevent the internal protection diode from conducting. The multiplier output is a current, making this a summing node and allowing a differential current error amplifier configuration to reject ground noise. The input resistance at this node should be 3.9k to minimize input bias current induced offset voltage. See the Applications section for the recommended circuit configuration.

**OUT:** Gate Driver Output. OUT provides high current gate drive for the external power MOSFET. A 15V clamp pre-

vents excessive MOSFET gate-to-source voltage so that the UC3853 can be operated with VCC and high as 40V. A series gate resistor of at least 5 ohms should be used to minimize clamp voltage overshoot. In addition, a Schottky diode such as a 1N5818 connected between OUT and GND may be necessary to prevent parasitic substrate diode conduction.

**ICOMP:** Current Loop Error Amplifier Output. The current loop error amplifier is a conventional operational amplifier with a 150μA current source class A output stage. Compensate the current loop by placing an impedance between ICOMP and IMO. This output can swing above the oscillator peak voltage, allowing zero duty cycle when necessary.

**VCC:** Input Supply Voltage. This pin serves two functions. It supplies power to the chip, and an input voltage level signal to the squarer circuit. When this input is connected to a DC voltage proportional to the AC input RMS voltage, the voltage loop gain is reduced by

$$\frac{64}{V_{CC}^2}$$

This configuration maintains constant loop gain. The UC3853 input voltage range extends from 12V to 40V, allowing an AC supply voltage range in excess of 85VAC to 265VAC. Bypass VCC with at least a 0.1μF ceramic capacitor to ensure proper operation. See the Applications section for the recommended circuit configuration.

**VCOMP:** Voltage Loop Error Amplifier Output. The voltage loop error amplifier is a transconductance type operational amplifier. A feedback impedance between VCOMP and FB for loop compensation must be avoided to maintain proper operation of the overvoltage protection comparator. Instead, compensate the voltage loop with an impedance between VCOMP and GND. When VCOMP is below 1.5V, the multiplier output current is zero.

UC3853 TYPICAL APPLICATION

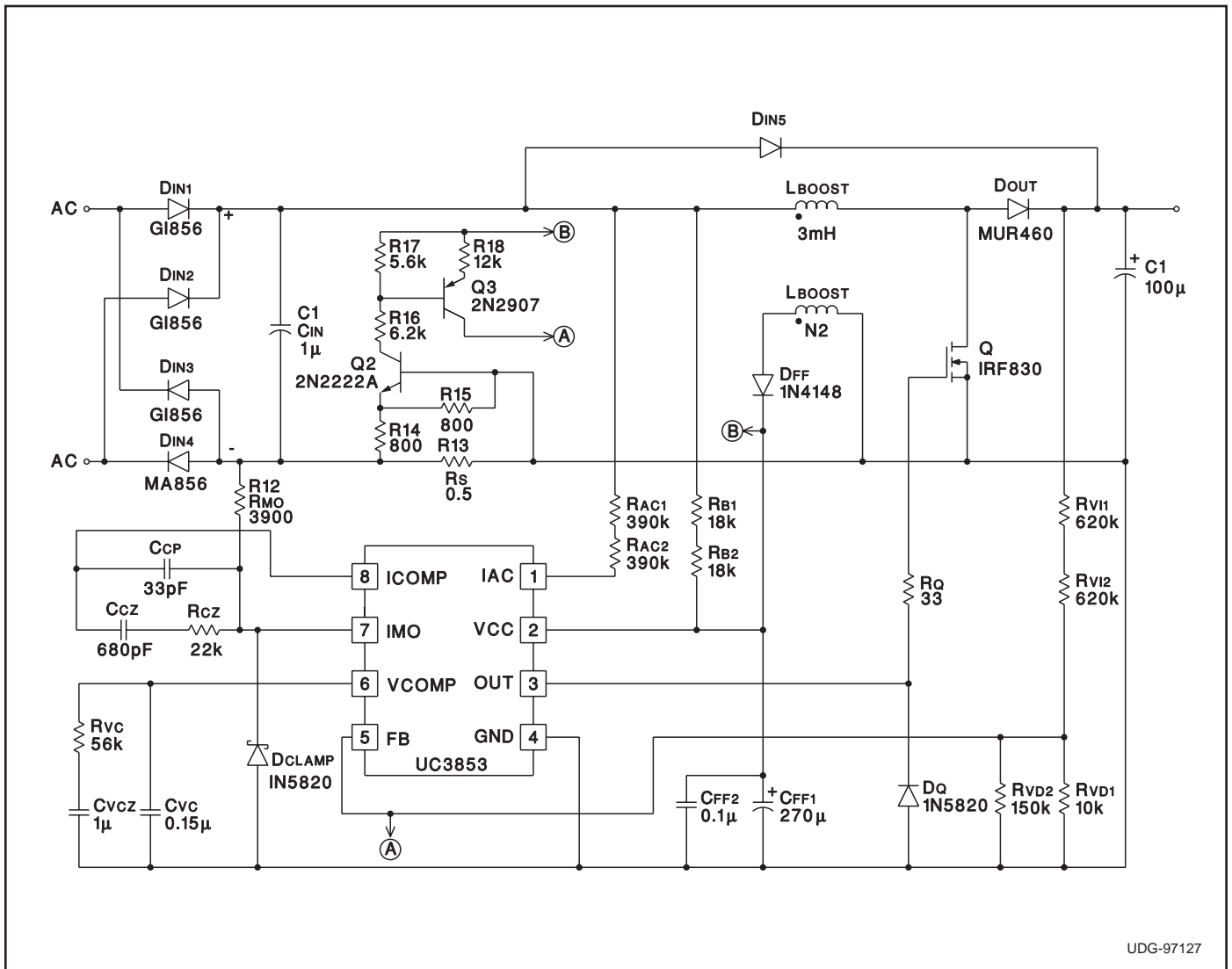

Note: the application circuit shown is a 100W, 75KHz design.  
Additional application information can be found in Application  
Note U-159 and Design Note DN-78.

## **IMPORTANT NOTICE**

Texas Instruments and its subsidiaries (TI) reserve the right to make changes to their products or to discontinue any product or service without notice, and advise customers to obtain the latest version of relevant information to verify, before placing orders, that information being relied on is current and complete. All products are sold subject to the terms and conditions of sale supplied at the time of order acknowledgement, including those pertaining to warranty, patent infringement, and limitation of liability.

TI warrants performance of its semiconductor products to the specifications applicable at the time of sale in accordance with TI's standard warranty. Testing and other quality control techniques are utilized to the extent TI deems necessary to support this warranty. Specific testing of all parameters of each device is not necessarily performed, except those mandated by government requirements.

**CERTAIN APPLICATIONS USING SEMICONDUCTOR PRODUCTS MAY INVOLVE POTENTIAL RISKS OF DEATH, PERSONAL INJURY, OR SEVERE PROPERTY OR ENVIRONMENTAL DAMAGE ("CRITICAL APPLICATIONS"). TI SEMICONDUCTOR PRODUCTS ARE NOT DESIGNED, AUTHORIZED, OR WARRANTED TO BE SUITABLE FOR USE IN LIFE-SUPPORT DEVICES OR SYSTEMS OR OTHER CRITICAL APPLICATIONS. INCLUSION OF TI PRODUCTS IN SUCH APPLICATIONS IS UNDERSTOOD TO BE FULLY AT THE CUSTOMER'S RISK.**

In order to minimize risks associated with the customer's applications, adequate design and operating safeguards must be provided by the customer to minimize inherent or procedural hazards.

TI assumes no liability for applications assistance or customer product design. TI does not warrant or represent that any license, either express or implied, is granted under any patent right, copyright, mask work right, or other intellectual property right of TI covering or relating to any combination, machine, or process in which such semiconductor products or services might be or are used. TI's publication of information regarding any third party's products or services does not constitute TI's approval, warranty or endorsement thereof.